

Detection Strategies

Eduardo Figueiredo

<http://www.dcc.ufmg.br/~figueiredo>

[Motivation]

- A metric alone cannot answer all questions about the system
 - Metrics must be used in combination
- A metric is too fine grained to be understood
 - We need to provide engineers with means to work with metrics at a more abstract level



[The Medical Metaphor]

- Metrics indicate the symptoms
 - A single symptom is not enough to provide an understanding of the disease
- A doctor may identify the disease based on several symptoms
 - A software engineer may identify the software problem based on several metrics

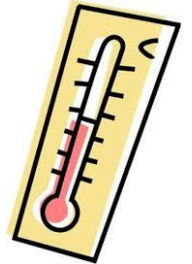

[Detection Strategies]

- A detection strategy is a composed logical condition, based on metrics, by which code fragments with specific properties are detected
- It relies on two mechanisms
 - Filtering
 - Composition

[Filtering Mechanism]

- Its goal is to reduce the data set
- Two types of filters
 - Absolute comparator uses classical comparison of numbers ($>$, $<$, \geq e \leq)
 - Relative comparator specifies the number of entities to be retrieved (i.e., relative to the original data)



[Notation of a Filter]

- Represented by a (rounded) rectangle
 - It includes an informal description of the filtering condition
 - It has a inner compartment (box) with the filtering formula

Informal description of a simple filtering condition

Metric > Threshold

[Composition Mechanism]

- It supports a interpretation of multiple result sets based on the AND and OR operators
- Notation

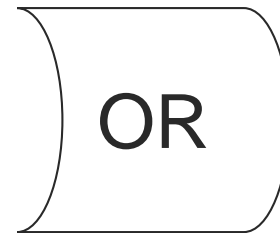
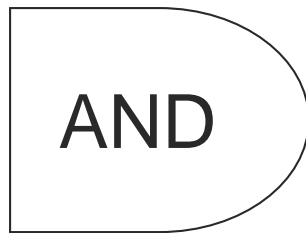

Abstract Example

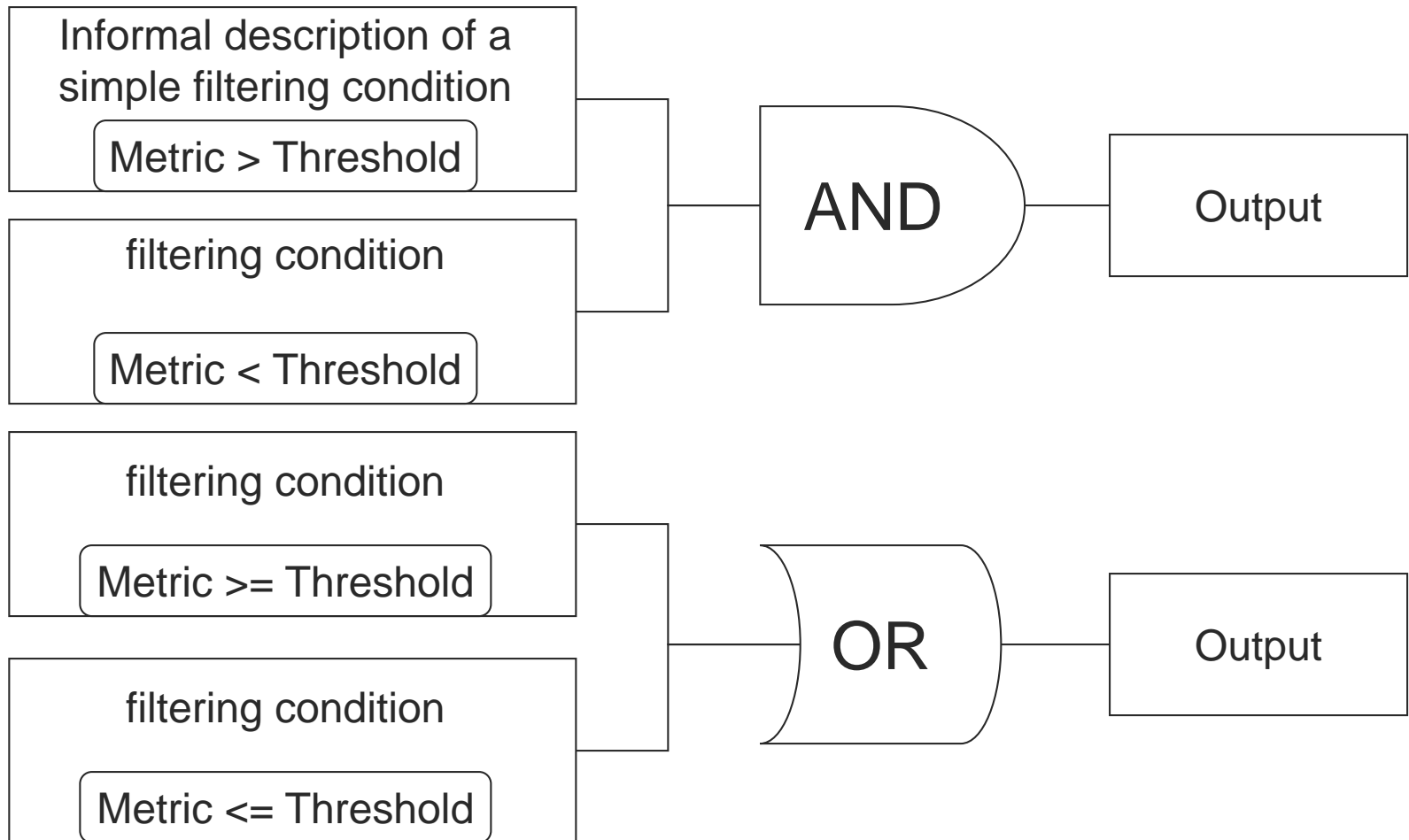

[Creating a Detection Strategy]

- Four steps can be used to define a detection strategy
 - **Identify Symptoms:** several symptoms are related to a disease; identify them
 - **Select Metrics:** you need one or more metrics to identify each symptom
 - **Select Filters:** define the thresholds to be used in filtering mechanisms
 - **Compose the Strategy:** correlate the symptoms using AND and OR operators

[Bibliography]

- M. Lanza e R. Marinescu. **Object-Oriented Metrics in Practice.** Springer, 2006.
 - Section 4.1 Detection Strategies